

Diaphragm



107 SERIES

115v/110v/230v/220v/12v

MODELS

Standard models

107CAB18

107CEF18

107CCD18

107CGH18

107CDC20

Other models based on availability and minimum purchase.

107CAB14

107CEF14

107CEF20

107CCD14

107CGH14

107CGH20

107CDC/C20



107CAB
107CCD



107CEF
107CGH



107CDC20

FEATURES

- Oil-less operation
- Permanently lubricated bearings
- Stainless valves
- Die cast aluminum head, valve plate and diaphragm hold down plate
- Balanced for smooth, low vibration operation
- Long-life diaphragm
- Field service capability
- UL® recognized motor and thermal protector (115 Volt, AC only)
- Inlet filter
- CE approval on all standard 220-240/50hz models
- Closed housing and motor vents (107CDC/C only)
- Consult factory for non-standard models
- Service Kit SK 107B

Consult factory for custom applications

ISO 9001
CERTIFIED

THOMAS
A Gardner Denver Product

107 Series Performance Data

MODEL NUMBER		107CCD14		Standard 107CCD18		107CGH14		Standard 107CGH18		107CGH20	
HEAD CONFIGURATION		Pressure/Vacuum		Pressure/Vacuum		Pressure/Vacuum		Pressure/Vacuum		Pressure/Vacuum	
STROKE		.140 Inches		.180 Inches		.140 Inches		.180 Inches		.200 Inches	
PRESSURE		Flow @ 230v/220v		Flow @ 230v/220v		Flow @ 230v/220v		Flow @ 230v/220v		Flow @ 230v/220v	
CFM @ PSI	LPM @ bar										
PSI	bar	CFM	LPM	CFM	LPM	CFM	LPM	CFM	LPM	CFM	LPM
0	0	.53 / .45	15.0 / 12.7	.65 / .55	18.4 / 15.6	.57 / .48	16.1 / 13.6	.69 / .59	20.0 / 16.7	.77 / .66	21.8 / 18.7
5	.5	.38 / .32	9.0 / 7.5	.51 / .43	13.0 / 11.0	.47 / .38	11.5 / 9.6	.63 / .52	16.3 / 13.7	.71 / .59	19.1 / 15.7
10	1.0	.24 / .20	4.5 / 3.9	.40 / .34	8.3 / 7.1	.33 / .29	6.3 / 5.7	.51 / .44	12.4 / 10.4	.63 / .51	15.3 / 11.9
15	1.5	.15 / .13	2.3 / 1.8	.28 / .24	5.2 / 4.4	.21 / .19	2.0 / 1.8	.43 / .36	8.8 / 7.4	.53 / .41	11.8 / 9.2
20	2.0	.10 / .08		.20 / .17	3.1 / 2.5	.20 / .17	3.1 / 2.5	.35 / .29	5.0 / 4.1	.44 / .35	8.7 / 6.3
25	3.0			.15 / .13		.10 / .09		.24 / .21		.37 / .28	
30				.10 / .08		.02 / .01		.16 / .13		.29 / .21	
35											
MAX. CONTINUOUS PRESSURE		20 PSI	1.4 bar	20 PSI	1.4 bar	20 PSI	1.4 bar	20 PSI	1.4 bar	20 PSI	1.4 bar
MAX. INTERMITTENT PRESSURE		20 PSI	1.4 bar	30 PSI	2.1 bar	25 PSI	1.7 bar	30 PSI	2.1 bar	30 PSI	2.1 bar
VACUUM		Flow @ 230v/220v		Flow @ 230v/220v		Flow @ 230v/220v		Flow @ 230v/220v		Flow @ 230v/220v	
CFM @ IN. hg	LPM @ mbar (gauge)										
IN. hg	mbar (gauge)	CFM	LPM	CFM	LPM	CFM	LPM	CFM	LPM	CFM	LPM
0	0	.53 / .45	15.0 / 12.7	.65 / .55	18.4 / 15.6	.57 / .48	16.1 / 13.6	.69 / .59	20.0 / 16.7	.77 / .66	21.8 / 18.7
5	-100	.35 / .30	12.0 / 10.2	.48 / .40	15.6 / 13.1	.43 / .34	13.8 / 11.3	.55 / .46	17.2 / 15.0	.62 / .52	19.3 / 16.3
10	-200	.21 / .18	9.2 / 7.9	.32 / .27	12.8 / 10.7	.27 / .21	11.4 / 9.0	.38 / .31	14.7 / 12.3	.44 / .37	16.6 / 14.0
15	-400	.09 / .07	4.7 / 4.0	.18 / .15	7.6 / 6.4	.12 / .10	6.1 / 4.8	.22 / .17	9.1 / 7.3	.27 / .22	10.7 / 9.0
20	-600				3.0 / 2.4		1.1 / 1.1	.07 / .05	4.0 / 3.0	.10 / .08	5.0 / 4.1
25	-800										
MAX. VACUUM		19.0" hg	-643 mbar	22.0" hg	-746 mbar	19.9" hg	-674 mbar	22.5" hg	-762 mbar	23.8" hg	-806 mbar
MAX. AMBIENT AIR TEMP.		104° F	40°C	104° F	40°C	104° F	40°C	104° F	40°C	104° F	40°C
MIN. AMBIENT START TEMP.		50° F	10°C	50° F	10°C	50° F	10°C	50° F	10°C	50° F	10°C
MAX. RESTART PRESSURE		0 PSI	0 bar	0 PSI	0 bar	0 PSI	0 bar	0 PSI	0 bar	0 PSI	0 bar
MAX. RESTART VACUUM		0" hg	0 mbar	0" hg	0 mbar	0" hg	0 mbar	0" hg	0 mbar	0" hg	0 mbar
MOTOR VOLTAGE/FREQUENCY		230/60/1-220/50/1		230/60/1-220/50/1		230/60/1-220/50/1		230/60/1-220/50/1		230/60/1-220/50/1	
MOTOR TYPE		Shaded Pole		Shaded Pole		Perm. Split Capacitor		Perm. Split Capacitor		Perm. Split Capacitor	
CURRENT AT RATED LOAD (AMPS)		.7 / .9		.8 / 1.0		.53 / .51		.60 / .62		.65 / .65	
POWER AT RATED LOAD (WATTS)		90 / 100		100 / 120		102 / 99		119 / 125		132 / 133	
STARTING CURRENT (LOCKED ROTOR, AMPS)		1.2		1.2		83 / .93		.83 / .93		.83 / .93	
CAPACITOR VALUE						5 mfd		5 mfd		5 mfd	
MIN. FULL LOAD SPEED (RPM)		1700 / 1390		1620 / 1220		1750 / 1450		1695 / 1340		1620 / 1210	
THERMAL PROTECTOR		Yes		Yes		Yes		Yes		Yes	
NET WEIGHT		5.1 lbs.	2.3 Kg	5.1 lbs.	2.3 Kg	6 lbs.	2.7 Kg	6 lbs.	2.7 Kg	6 lbs.	2.7 Kg

Dimensions

107CCD

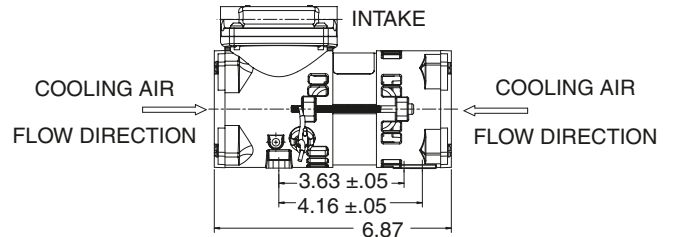
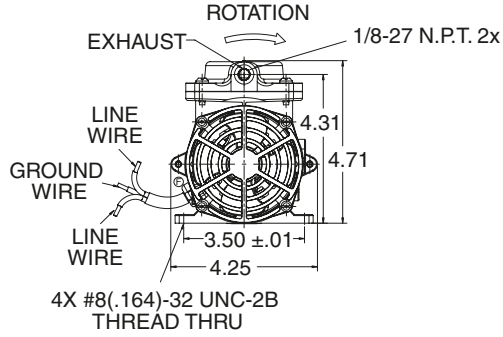

107CGH

CAPACITOR HEIGHT
FLUSH TO HEAD, ± .25"

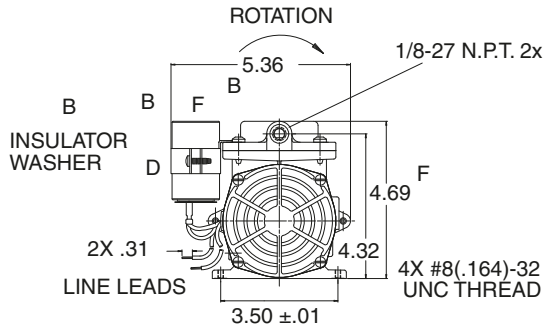

CAPACITOR LEADS
2X 605215 FEMALE
QUICK DISCONNECTS
(.250 X .032 TABS)

